

ROCOL®

MACHINE SHOP SOLUTIONS

Performance you can trust



From product concept, design and development through to technical expertise and customer services, ROCOL® supports all your machine shop needs.

Contents

Hand Applied Cutting Lubricants	4 to 7
Cutting Fluids	8 to 9
Fluid Care Products and Equipment	10
Slideaway Lubricants and Cleaner	11
Corrosion Protectives	12
Mould Release	13
Metal Marking Inks	14
Non-Destructive Testing System (NDT)	15
Welding and Fabrication	16
Glass Production	17
Hot Metal Forging Lubricants	18
Knowledge Centre	19

The sectors we serve

- ▶ CNC Machine Shops
- ▶ Welding and Fabrication
- ▶ Plastic Injection Moulding
- ▶ Cold Metal Forming
- ▶ Hot Metal Forging
- ▶ Glass Production

Performance you can trust for the metalworking industry



Technically advanced lubricants developed by our chemists and engineers to meet customer needs.

Our metalworking products:

- ▶ Extend tooling and component life
- ▶ Reduce machine downtime
- ▶ Reduce tooling costs and breakages
- ▶ Increase productivity
- ▶ Minimise the risk of workpiece rejection and scrappage

ROCOL provides one of the industry's widest portfolios of high performance products used in the many applications found within today's machine shop.

ROCOL products are developed and manufactured in the United Kingdom and supplied to engineers globally. They provide a comprehensive tool box of solutions keeping machine shops running effectively and efficiently.

We help improve quality throughout all machine shop processes and ensure our customers get it right first time. We welcome the opportunity to meet the needs of our customers with end user visits and site surveys.

Our dedicated labs test to ISO, ASTM, BSI and IP standards so you can be assured that you're using the highest quality products.

Hand Applied Cutting Lubricants

Reaming, Tapping and Drilling Lubricants



METAL CUTTING LUBRICANT



REAMING, TAPPING & DRILLING

Suitable for use on many metal types including medium and difficult materials

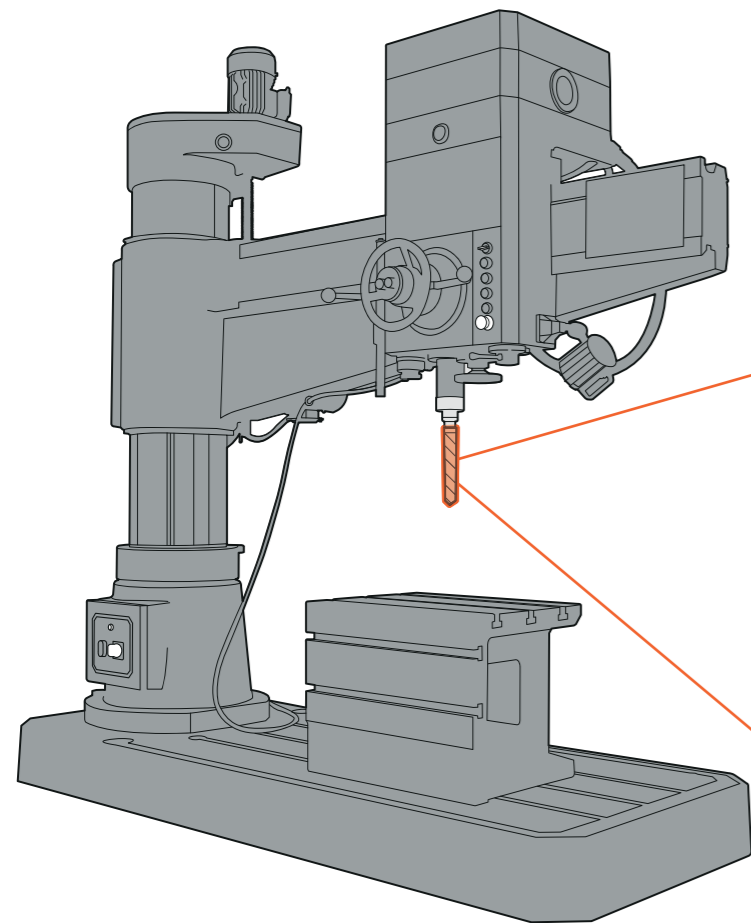

RTD LIQUID



- ▶ Flows to the cutting edge
- ▶ Solvent free
- ▶ Available in a plastic squeeze bottle for easy application



Part code	Size
53072	400 g
53076	5 L
53078	20 L

RTD COMPOUND



- ▶ Soft low melting-point paste
- ▶ Formulated to cling to the tool - stays where it needs to be for longer
- ▶ NATO Stock Number: 9150 99 220-2775
- ▶ NATO Stock Number: 9150 99 464-6766



Part code	Size
53020	50 g
53023	500 g
53026	5 kg
53028	18 kg

100% CHLORINE FREE FORMULATION

RTD CHLORINE-FREE LIQUID

Part code	Size
53521	350 mL
53526	5 L



RTD CHLORINE-FREE COMPOUND

Part code	Size
53513	450 g



The RTD® range of hand applied cutting lubricants are uniquely formulated, providing superior performance across a range of ferrous and non-ferrous metals.

The Reichert Wear Test is a recognized method for assessing the extreme pressure (EP) performance of lubricants and cutting fluids.

It simulates sliding conditions under load via a pin-on-ring based test to evaluate how effectively a product minimizes wear. Lower wear percentages indicate superior protection. RTD consistently delivers industry-leading performance in this test, giving engineers the confidence to push machining limits on any material without compromising tool life.

This is performance you can trust.



Scan the QR code to learn more about the Reichert Wear Test



Reichert Wear Test Results

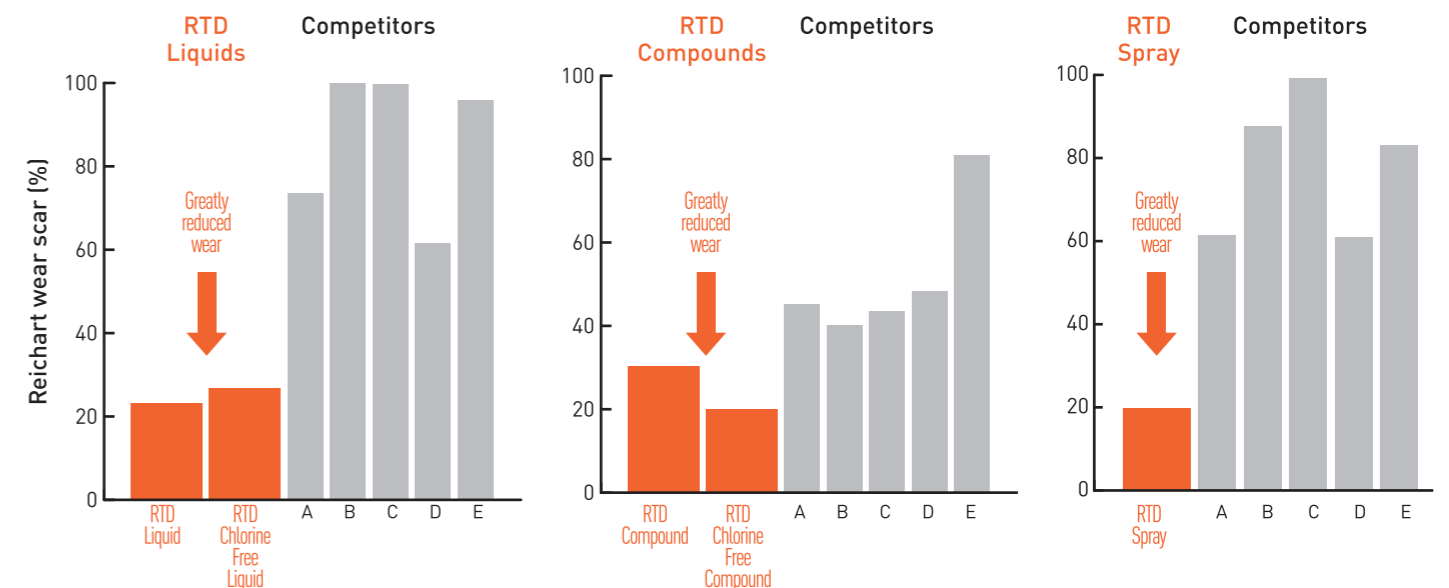



Hand Applied Cutting Lubricants

Reaming, Tapping and Drilling Lubricants



METAL CUTTING LUBRICANT

The RTD® range of hand applied cutting lubricants are uniquely formulated, providing superior performance across a range of ferrous and non-ferrous metals.



REAMING, TAPPING & DRILLING

Suitable for use on many metal types including medium and difficult materials. Can be used for deep hole drilling and boring.

RTD FOAMCUT



- ▶ Clean, low odour foaming spray
- ▶ Foaming action adheres to the tool - stays where it needs to be for longer
- ▶ Rapidly penetrates to the cutting edge - gets where it needs to be quickly

Part code	Size
53041	300 mL



RTD SPRAY



- ▶ NATO Stock Number: 9150 99 541-7134
- ▶ Quick and convenient to use

Part code	Size
53011	400 mL



100% CHLORINE FREE FORMULATION

RTD CHLORINE-FREE SPRAY

Part code	Size
53081	400 mL

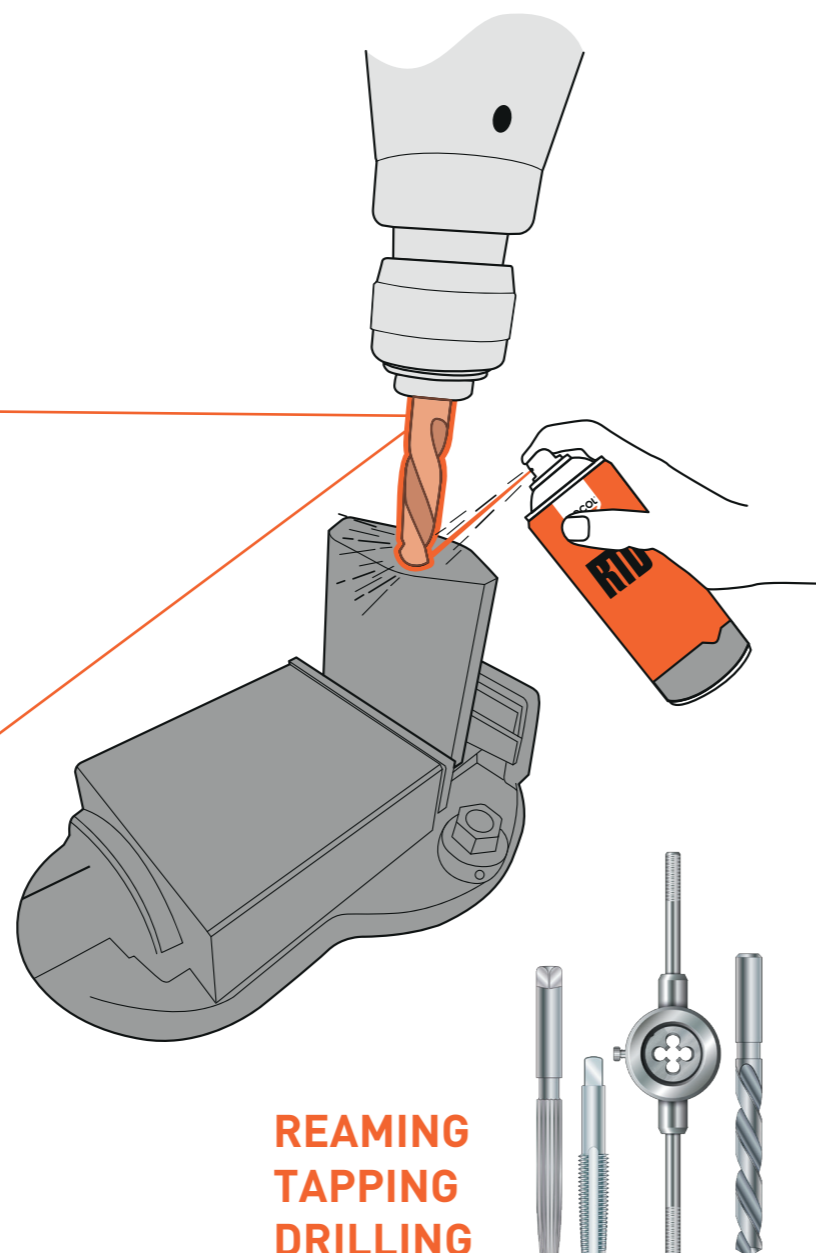

REAMING
TAPPING
DRILLING



Emulsifies with water mix cutting fluids.

RTD CLEAN CUT



- ▶ Sulphur and chlorine free
- ▶ Can be diluted up to 1:1 with water for double economy on light operations
- ▶ Available in a plastic squeeze bottle for easy application
- ▶ Particularly useful on aluminium and yellow metals
- ▶ This product is Class A approved by the Rolls Royce Non Metallic Database

Part code	Size
53062	350 g



Slideway Lubricants

ULTRAGLIDE contains high quality oils and additives that provide lubrication and corrosion protection for machine tool slideways.



SLIDEWAY LUBRICANT

Total protection slideway lubricant

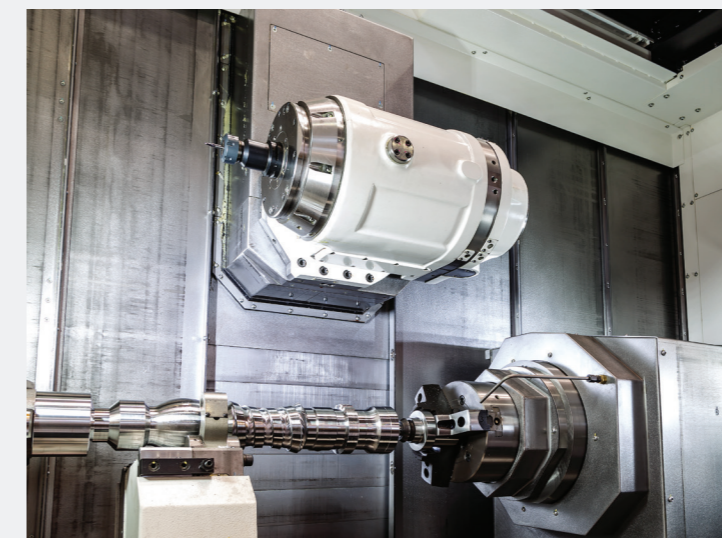

ULTRAGLIDE X5



- ▶ Highly tenacious film - resistant to water wash off/ protects slides from corrosion
- ▶ Good lubrication and load carrying properties - reduces wear and prevents 'stick slip'
- ▶ Rapid demulsification - separates rapidly from cutting fluid and easily removed by oil skimmers/separators

Part code	Size
52041	400 mL
52083	20 L
52089	200 L





Cutting Fluids

Market leading cutting fluids



CUTTING FLUID

The ROCOL® V-cut™ range of cutting fluids and maintenance oils provides trusted performance and quality at a highly competitive price. ROCOL is a market leader in cutting performance and dilution which means our cutting fluids and your tools last longer.

V-CUT MP



- ▶ Milky type water mix fluid for all general cutting operations
- ▶ Used on various metals, with excellent results on low to medium carbon steels
- ▶ Very economical dilutions, up to 35:1

Part code 51543 **Size** 20 L

V-CUT SS



- ▶ Semi-synthetic water mix fluid for all general cutting and grinding operations
- ▶ Allows rationalization to one product for cutting and grinding
- ▶ Used on most metals especially low to medium carbon steels
- ▶ Extremely economical dilutions, up to 65:1

Part code 51523 **Size** 20 L

V-CUT EP



- ▶ Extreme pressure water mix fluid for heavy duty cutting operations
- ▶ Contains extreme pressure additives enabling best performance when machining harder materials such as hardened steels or similar tough alloys
- ▶ Extended tool life and faster machining rates providing cost savings on expensive tooling
- ▶ Very economical dilutions, up to 35:1

Part code 51533 **Size** 20 L



MORE CHOICE

Complete range of fluid solutions for the machine shop:

- Cutting fluid
- Slideway oil
- Hydraulic oil

MORE PERFORMANCE

Specially selected lubricity additives help to extend tool life and improve surface finish

MORE ECONOMY

With highly economical dilutions (up to 65:1) and prolonged sump life, V-cut goes at least twice as far as similar cutting fluids

MORE PEACE OF MIND

Used with ROCOL fluid mixer, V-cut products keep the workplace clean and help reduce health and safety issues

LESS COST

V-cut products give you the quality and performance expected from ROCOL at a competitive price

	V-CUT EP	V-CUT MP	V-CUT SS
FUNCTION	Cutting fluid	Cutting fluid	Cutting/grinding fluid
SUITABILITY	Medium to heavy duty	General purpose	General cutting and grinding
EMULSION COLOUR	Milky white	Milky white	Translucent green
FLUID TYPE AND TYPICAL DILUTION RATIO	Soluble oil up to 35:1	Soluble oil up to 35:1	Semi-synthetic up to 65:1
MATERIAL SUITABILITY	CAST IRON	★★★★★	★★★★
	ALUMINIUM	★★★★	★★★★
	COPPER ALLOYS	★★★★	★★★★
	LOW-MEDIUM CARBON STEELS	★★★★★	★★★★★
	HARDENED ALLOYS	★★★★★	★★★★
METAL CUTTING	GENERAL OPERATION	★★★★★	★★★★★
	HEAVY DUTY OPERATION	★★★★★	★★★★
GRINDING	★★★★	★★★★	★★★★★
PACK SIZES	20L	51533	51543
	55L	51530	-

KEY TO PERFORMANCE ★ NOT SUITABLE ★★ OK ★★★ GOOD ★★★★ VERY GOOD ★★★★★ EXCELLENT

Fluid Care Products and Equipment

Our ULTRAGUARD® range of machine tool care products work with our water mix metalworking fluids to ensure your ROCOL® cutting fluid is in optimum condition and your machines and operators are cared for.



FLUID CARE PRODUCTS AND EQUIPMENT

Multi-Purpose Cleaner



CLEANER

ULTRAGUARD BX 2000



Bactericide additive

- ▶ Dilution ratio 2000:1 – economical in use
- ▶ Formulated to provide long lasting protection against bacterial contamination

Part code 52082 **Size** 5 L

TROYSHIELD PA10



Fungicide additive

- ▶ Eliminates fungal growths
- ▶ Prevents blockages in pipework due to fungal growths

Part code 52095 **Size** 5 L

ULTRAGUARD AF 5000



Non-silicone antifoam

- ▶ Dilution ratio 10000:1 – economical in use
- ▶ Antifoam formulated for the treatment of all types of water mix metalworking fluids
- ▶ Effectively controls excessive foaming

Part code 52075 **Size** 5 L

ULTRAGUARD SC



Machine tool system cleaner

- ▶ Dilution ratio 100:1 – economical in use
- ▶ Cleans and disinfects in one operation
- ▶ For use prior to recharging machine tools with fresh cutting / grinding fluid

Part code 52023 **Size** 20 L



ROCOL Automatic Fluid Mixer

- ▶ Accurately mixes and dispenses water mix cutting and grinding fluids from the barrel

Part code 52233



MULTI-PURPOSE WATER BASED CLEANER

ULTRACLEAN 2000 is a highly effective water based multi-purpose cleaner. Its primary use is the fast and easy removal of oils and greases.



ULTRACLEAN 2000

Multi-purpose water based cleaner

- ▶ Fast easy removal of oils and greases
- ▶ Use on virtually any non-porous surface
- ▶ Leaves no residue when rinsed away
- ▶ Economical – dilution range up to 100:1
- ▶ Used for ultrasonic baths, cleaning floors and pressure washers

Part code 51059 **Size** 200 L



ROCOL Refractometer

- ▶ Provides accurate read out (strength/ mix ratio) of water mix cutting and grinding fluids

Part code 52060



Corrosion Protectives

Moisture Guard is a medium to long indoor corrosion protection solution for bare metal components and mould tools. It is used to protect high value moulding tools and bright metal components in storage, particularly where condensation is a problem.



CORROSION PROTECTION

Mould Release

Our mould release agents give fast, efficient and clean release of all types of plastics and rubbers. They provide faithful reproduction of the mould profile however complex the mould or minute the detail. They are commonly used in injection and compression mouldings, as well as extrusion and glass fibre lay up work.



MOULD RELEASE

MOISTURE GUARD SPRAYS

Five year indoor corrosion protective

- ▶ Flexible film – does not chip or crack
- ▶ Dewatering film protects against corrosion caused by moisture or damp atmospheres
- ▶ Protects against condensation attack
- ▶ Does not attract dirt or dust
- ▶ Silicone free
- ▶ Does not normally require removal prior to use
- ▶ Available in clear and green formulations
- ▶ After 1000 hrs accelerated humidity cabinet testing, MOISTURE GUARD treated steel remains free from corrosion

CLEAR SPRAY

Part code	Size
69025	400 mL

GREEN SPRAY

Part code	Size
69045	400 mL

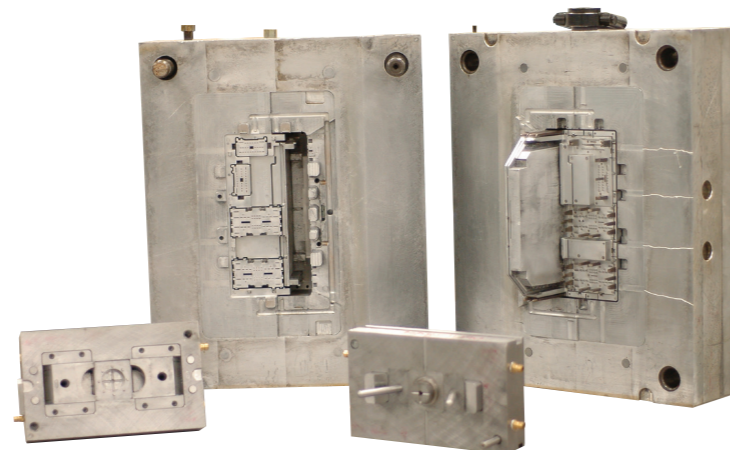
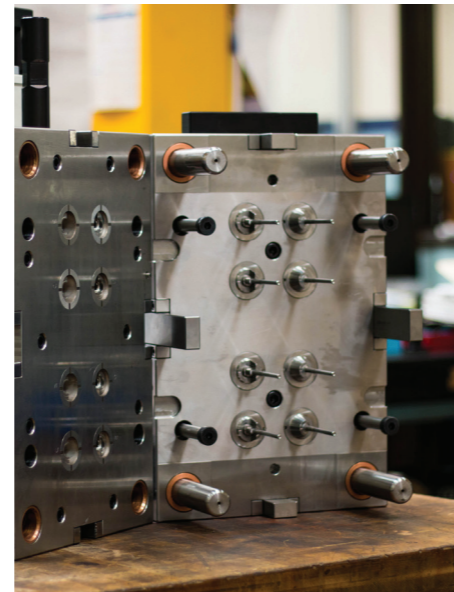

PR SPRAY



Long lasting silicone mould release

- ▶ Release agent where silicones can be tolerated
- ▶ Wet film promotes gloss finish
- ▶ Ultra fine even film gives controlled application with complete coverage
- ▶ Suitable up to 200°C

Part code	Size
72015	400 mL

MOULD RELEASE SPRAY



Long lasting PTFE mould release

- ▶ Ultra thin non-silicone dry film PTFE release agent
- ▶ Can be over-painted or printed
- ▶ Suitable up to 270°C

Part code	Size
72021	400 mL

ULTIMATE SILICONE SPRAY



The ultimate high work-rate silicone spray with enhanced spray distance, superior film formation and a 360° spray function.

- ▶ Optimised impression count per can, helping reduce changeover frequency and overall spray usage.
- ▶ A long spray reach of up to 0.8 metres ensures faster application to larger surface areas.
- ▶ 30% more silicone content compared to standard competitor products for longer-lasting protection and reduced reapplication.
- ▶ Suitable up to 200°C

Part code	Size
34045	400 mL



Nonfood Compounds Program Listed H1 171313 ISO 21469 Certified



Metal Marking Inks

Our LAYOUT INK provides faster, cleaner, more accurate marking out on all metal and plastic surfaces. It gives a smooth even film, enabling clear sharply defined lines to be scribed easily on all surfaces without chipping.



LAYOUT INK SPRAY/FLUID

Metal Marking Ink

- ▶ Fast drying
- ▶ Easily removable
- ▶ Forms an even thin film
- ▶ Provides contrast and definition
- ▶ Scribes without flaking or chipping
- ▶ Blue for bright surfaces, white for dark surfaces

BLUE SPRAY

Part code 57015 **Size** 400 mL

BLUE FLUID

Part code 57034 **Size** 1 L

WHITE SPRAY

Part code 57025 **Size** 400 mL



USED BY

- Toolroom
- Engineering workshops
- Maintenance departments
- Production machining
- Fabricators



Non-Destructive Testing System (NDT)

Our FLAWFINDER non-destructive inspection system provides a fast, reliable method for visible detection of cracks or flaws which would not normally be visible to the naked eye. Used to inspect welded joints, castings, forgings on many different materials.



FLAWFINDER CLEANER SPRAY

Fast drying, no residue cleaner

- ▶ Cuts through dirt, grease and grime
- ▶ Zero residue
- ▶ Prepares surface for non-destructive testing

Part code 63125 **Size** 300 mL



Cleaner



Penetrant



FLAWFINDER DYE PENETRANT SPRAY

Precision crack detection penetrant

- ▶ Bright red even film
- ▶ Highly sensitive dye
- ▶ Water washable

Part code 63151 **Size** 400 mL

FLAWFINDER DEVELOPER SPRAY

Precision crack detection penetrant

- ▶ Highly absorbent white film for rapid results
- ▶ Highlights very fine cracks
- ▶ Sharp indication and geometry of defect to the naked eye

Part code 63135 **Size** 400 mL



Developer



FLAWFINDER KIT

- ▶ All three products in one convenient kit
- ▶ Useful for remote testing or for mobile engineers

Part code 63181 **Size** 3x Aerosols





Welding and Fabrication

Our SPATTER RELEASE prevents the adhesion of molten weld spatter to the work piece, fixtures, jigs, shrouds and nozzles. They provide a cost effective even film with excellent spatter release properties.



WELD SPATTER
RELEASE

Glass Production

Our GLASSFLO products are lubricants and coatings that assist production in the glass manufacturing industry.



GLASS
LUBRICANT

SPATTER RELEASE SPRAY

Long lasting non-flammable spatter release

- ▶ One pass coating - goes further / lasts longer
- ▶ Film allows multiple welds
- ▶ Silicone free
- ▶ Easy cleaning

Part code	Size
66080	400 mL



GLASSFLO 2017



Dry graphite lubricant

- ▶ Dry lubricant for wire mesh belts and slide plates found on glass container making machines
- ▶ Reduces thermal shock between hot glass and cold transfer plate or belt
- ▶ Reduces crizzling and thermal marking

Part code	Size
78836	4.5 kg



GLASSFLO 785

High performance dry delivery coating

- ▶ Dry coating system for scoops, troughs and deflectors used on all types of glass forming delivery equipment
- ▶ Gives consistent delivery speed
- ▶ Suitable for patch coating

Part code	Size
78844	500 g



GLASSFLO MPT

Mould pre-treatment spray

- ▶ Formulated to remove the need for manual swabbing of moulds during start up
- ▶ Clean, air cured, dry coating - requires no baking
- ▶ Prevents adhesion of ware to moulds

Part code	Size
78871	400 mL



Hot Metal Forging Lubricants

Our METALFLO products are lubricants to assist manufacturing in the forging industry.



Knowledge Centre

ROCOL® is synonymous with quality and that reputation comes from developing technically advanced products for demanding industry applications.

We develop products that display significant advantages over the competition, advantages that add true value to our customers.

METALFLO 2064

Semi-colloidal dispersion of graphite in water

Part code **78344** Size **18 kg**

- ▶ Lubricates closed dies in ferrous forging or as a parting agent in gravity die casting
- ▶ Withstands temperatures of up to 650°C
- ▶ Can be extended with water, up to 10:1, making it last longer than other solutions



METALFLO 4000

Dispersion of graphite in water

Part code **78543** Size **20 L**

- ▶ Used on drop hammers and press forgings
- ▶ Controls die temperature and extends die life
- ▶ Can be extended with water, up to 20:1, making it last longer



We formulate and test our products in-house but, also carry out independent testing which means that you can be sure that you are using the best product for the job.

To guarantee we achieve this, ROCOL's team of chemists and engineers develops all products in accordance with the ISO 9001 system and is certified to internationally recognised standards.

Each batch of every product we manufacture is tested by the experienced personnel in our quality control laboratory and released for use only when we are confident that it meets the high standards of quality and superior performance associated with all ROCOL products: performance you can trust.

Our products exist to serve you. By working within our AS 9100:2016 and ISO 9001:2015 accredited quality management systems, we ensure that we continue to deliver products that exceed our customer expectations. From product concept and design through to technical expertise and customer services, all the functions at ROCOL are carefully controlled, meaning you consistently get what you need.

- ▶ Technically advanced products for demanding industry applications
- ▶ Products formulated and tested in-house as well as to industry standards
- ▶ All products developed in accordance with AS 9100:2016 and ISO 9001:2015 accredited Quality Management System
- ▶ Each product tested in our quality control laboratory – only released when ready for use in your applications

UK sales

We have a teams of dedicated account handlers across the UK who are ready to help you.

Sales Area 1&5

Ian Fenney

M: 07730 486838

E: ian.fenney@rocol.com

North Service Engineer

Graeme Herd

M: 07901 112269

E: graeme.herd@rocol.com

Sales Area 2

Vicky Curtis

M: 07353 103864

E: vicky.curtis@rocol.com

North Service Engineer

Graeme Herd

M: 07901 112269

E: graeme.herd@rocol.com

South Service Engineer

Corey Muddimer

M: 07730 486836

E: corey.muddimer@rocol.com

Sales Area 3

Lee Edwards

M: 07825 203769

E: lee.edwards@rocol.com

South Service Engineer

Corey Muddimer

M: 07730 486836

E: corey.muddimer@rocol.com

Sales Lead – Process Lubricants

Ian Fenney

M: 07730 486838

E: ian.fenney@rocol.com

Head of Business Development

Alan Rankin

M: 07785 324318

E: alan.rankin@rocol.com

Internal Lab/Tech Support

E: technical.lubricants@rocol.com

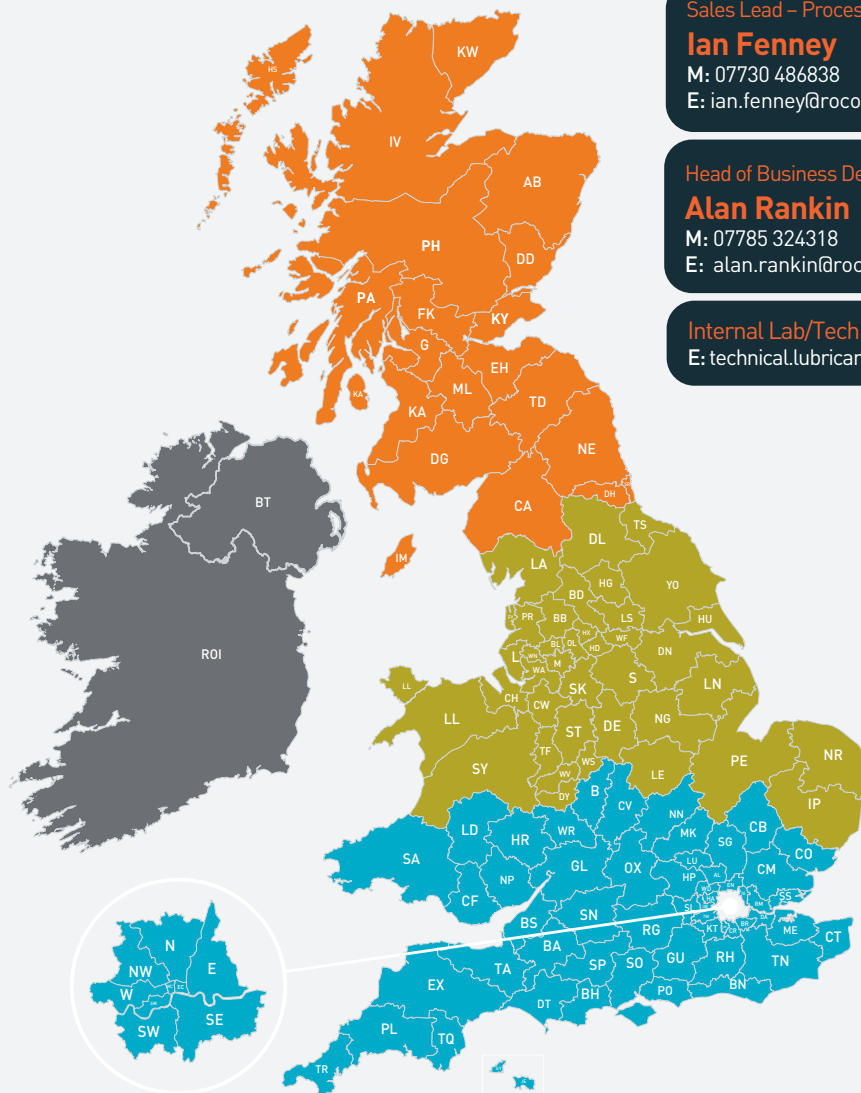

ROCOL® House, Swillington, Leeds LS26 8BS

T +44 (0) 113 232 2600

F +44 (0) 113 232 2740

E customer.service@rocol.com

Part of ITW www.itw.com

www.rocol.com

ROCOL® A division of **ITW** Ltd



ISO 9001
Quality
Management
Systems
CERTIFIED

FM 12448

AS/EN
9100
Aerospace and
Defence
CERTIFIED

FM 667905

ISO 14001
Environmental
Management
CERTIFIED

EMS 67596

ISO/IEC
27001
Information Security
Management
CERTIFIED

IS 702007

ISO 45001
Occupational
Health and Safety
Management
CERTIFIED

OHS 78173



INVESTORS
IN PEOPLE